

PREMIUM QUALITY Carbide Cutting Rings and Cutting Ring Holders for mechanical and hydraulic inside tube scarfing systems

alpha Metall

Different Coating Systems Available

- TiN (PVD) • CVD-TiC/TiN
- TiAlN • CVD Al₂O₃

Supercoatings for Special Applications

- Hyperlox® • Exxtral®

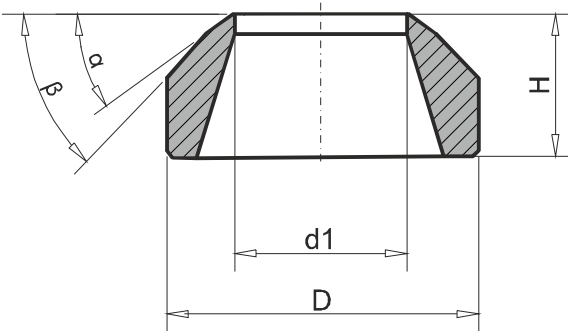

- Premium carbide quality for long service life.
- Very narrow tolerances for repeatable scarfing results.
- Precise cutting edge honing for perfect scarfing surface finish and long service life.
- Special cutting geometry for high strength materials available on request.

● Uncoated

Standard Coatings

● TiN ● Al₂O₃ ● TiC/TiN Multilayer

Cutting Ring	D [mm]	d1 [mm]	H [mm]	Standard Profile Cutting Ring Holder	Slant Profile Cutting Ring Holder
0-AL-3,5 (SR0/AR3,5) ● 0-AL 4,0 (SR0/AR4,0) ●●	6,0	3,0 3,5	3,5 3,5		
0-AL-4,5 (SR0/AR4,5) ●● 0-AL 5,5 (SR0/AR5,5) ●●	8,0	4,0 5,0	4 4	014-CRH 4,5 (SH0/SR4,5)	014-CRHT 4,5
0-AL-6,0 (SR0/AR6) 0-AL 6,5 (SR0/AR6,5) ●● 0-AL 7 (SR0/AR7) ●● 0-AL 8 (SR0/AR8) ●●	10,0	5,5 6,0 6,5 7,5	4,5 4,5 4,5 4,5	017-CRH 6,5 (SH0/SR6,5) 1-CRH 6,5 (SH1/SR6,5)	017-CRHT 6,5 1-CRHT 6,5
1-AL 7 (SR1/AR7) ●● 1-AL 8 (SR1/AR8) ●● 1-AL 9 (SR1/AR9) ●● 1-AL 10 (SR1/AR10) ●●	13,0	6,0 7,0 8,0 9,0	5 5 5 5	1-CRH 1 (SH1/SR1) 2-CRH 1 (SH2/SR1) 3-CRH 1 (SH3/SR1)	1-CRHT 1 2-CRHT 1 3-CRHT 1
2-AL 10 (SR2/AR10) ●● 2-AL 11 (SR2/AR11) ●● 2-AL 12 (SR2/AR12) ●●	19,0	9,0 10,0 11,0	8 8 8	2-CRH 2 (SH2/SR2) 3-CRH 2 (SH3/SR2)	2-CRHT 2 3-CRHT 2
3-AL 14 (SR3/AR14) ●● 3-AL 17 (SR3/AR17) ●●	22,0	12,0 15,0	10 10	3-CRH 3 (SH3/SR3) 4-CRH 3 (SH4/SR3)	3-CRHT 3
4-AL 23 (SR4/AR23) ●●	30,0	20,0	12	4-CRH 4 (SH4/SR4) 5-CRH 4 (SH5/SR4)	
5-AL 25 (SR5/AR25) ●● 5-AL 28 (SR5/AR28) ●●	35,0	22,0 25,0	12 12	5-CRH 5 (SH5/SR5) 6-CRH 5 (SH6/SR5)	
6-AL 34 (SR6/AR34) ●●●	45,0	30,0	15	6-CRH 6 (SH6/SR6)	
7-AL 39 (SR7/AR39) ●●●	50,0	35,0	15	6-CRH 7 (SH6/SR7)	
8-AL 46 (SR8/AR39) ●●●	55,0	40,0	18	6-CRH 8 (SH6/SR8)	

The above "CRHT" cutting ring holders fit only in our IST type Scarfing Tools.